



**HAL**  
open science

# IP-Based Mobility Management and Handover Latency Measurement in heterogeneous environments

Ahmad Rahil, Olivier Togni, Nader Mbarek

► **To cite this version:**

Ahmad Rahil, Olivier Togni, Nader Mbarek. IP-Based Mobility Management and Handover Latency Measurement in heterogeneous environments. *Network and Complex Systems*, 2017, 7 (1), pp.26-49. hal-01859065

**HAL Id: hal-01859065**

**<https://u-bourgogne.hal.science/hal-01859065v1>**

Submitted on 15 Jun 2022

**HAL** is a multi-disciplinary open access archive for the deposit and dissemination of scientific research documents, whether they are published or not. The documents may come from teaching and research institutions in France or abroad, or from public or private research centers.

L'archive ouverte pluridisciplinaire **HAL**, est destinée au dépôt et à la diffusion de documents scientifiques de niveau recherche, publiés ou non, émanant des établissements d'enseignement et de recherche français ou étrangers, des laboratoires publics ou privés.



Distributed under a Creative Commons Attribution - NonCommercial 4.0 International License

# IP-Based Mobility Management and Handover Latency Measurement in heterogeneous environments

Ahmad Rahil<sup>1\*</sup> Olivier Togni<sup>2</sup> Nader Mbarek<sup>3</sup>

1. Faculty of Business, Lebanese University, Nabatieh, Lebanon
2. LE2I laboratory, Burgundy University, 9, avenue A. Savary, 21078 Dijon Cedex, FRANCE
3. LE2I laboratory, Burgundy University, 9, avenue A. Savary, 21078 Dijon Cedex, FRANCE

\* E-mail of the corresponding author: a\_rahil@hotmail.com

## Abstract

One serious concern in the ubiquitous networks is the seamless vertical handover management between different wireless technologies. To meet this challenge, many standardization organizations proposed different protocols at different layers of the protocol stack. The Internet Engineering Task Force (IETF) has different groups working on mobility at IP level in order to enhance mobile IPv4 and mobile IPv6 with different variants: HMIPv6 (Hierarchical Mobile IPv6), FMIPv6 (Fast Mobile IPv6) and PMIPv6 (Proxy Mobile IPv6) for seamless handover. Moreover, the IEEE 802.21 standard provides another framework for seamless handover. The 3GPP standard provides the Access Network and Selection Function (ANDSF) to support seamless handover between 3GPP – non 3GPP networks like Wi-Fi, considered as untrusted, and WIMAX considered as trusted networks. In this paper, we present an in-depth analysis of seamless vertical handover protocols and a handover latency comparison of the main mobility management approaches in the literature. The comparison shows the advantages and drawbacks of every mechanism in order to facilitate the adoption of the convenient one for vertical handover within Next Generation Network (NGN) environments.

**Keywords:** Seamless vertical handover, mobility management protocols, IEEE 802.21 MIH, handover latency

## 1. Introduction

The rapid growth of real-time wireless applications usage implies a need for continuous network technologies improvement in order to support their QoS requirements in such a rapidly evolving environment. To successfully satisfy this increasing demand while providing end-users with QoS guarantee, the ubiquitous network should allow a Mobile Node (MN) to do handover between different types of network in a flexible manner. In order to enhance the end-user experience, in such environments, and achieve a given service level guarantee, a MN needs to roam seamlessly between different wireless access networks within any Next Generation Network (NGN) architecture. When a MN changes its point of attachment, it acquires a new IP address from the newly visited network and loses all previous connections with the home network. Different IETF working groups and other standardization bodies propose different protocols to manage seamlessly IP-based mobility. The research work in mobility management specifies two main categories: macro-mobility that is the transition of a mobile user between two different networks and micro-mobility when a mobile node changes its point of attachment within the same network. Mobile IPv4 is the most widely used protocol for macro-mobility management while FMIPv6 and HMIPv6 are more suitable for a micro-mobility management where the mobile node changes often its point of attachment.

Extension and optimization for IP mobility has been widely explored in the literature even for micro and macro-mobility management schema *Zekri et al. (2012)* did an extensive overview of mobility management protocols. They provided an indepth comparison of the different heuristics used in this domain and classified them into categories along with their respective advantages and disadvantages. In an attempt to expand this research, *Yan et al. (2010)* have had a similar research done. Their distinction was to provide three additional criteria to compare the heuristics; namely: number of handovers, handover failure probability and throughput. On a similar track, *Barja et al. (2011)* classified the most widely used vertical handover decision algorithm (VHA) in the literature into different sets of algorithms depending primarily on the information used to make decisions and the techniques employed. They concluded by providing recommendations on the most appropriate vertical handover techniques to efficiently communicate in heterogeneous environments based on their particular and unique network characteristics. In this research, we do an empirical handover latency study for the most known mobility management protocols: MIPv4,

MIPv6, HMIPv6 and FMIPv6 and we compare the pros and the cons of each studied schema. At the same time, we did a comparative study on the most significant work, using MIH, to improve the handover latency during the handover period.

The remainder of this paper is organized into 12 different sections covering our research. In section 2 describes the related work. Section 3 describes the main standardization bodies for handover management. Section 4 provides an overview of different handover categories. Section 5 shows the handover process phases. Section 6 discusses the different protocols used for handover at different layers. In section 7, we study and compare in detail the handover latency and its causes according to four different IP based protocols. Section 8 discusses the handover latency with the mSCTP protocol. Section 9 describes the SIP protocol and the handover latency. In Section 10, we present an overview of the IEEE 802.21 standard. In section 11 we compare the proposed research for minimizing handover latency and we finally conclude by Section 12.

## 2. Related Work

Handover is the process that enables a MN to change its point of attachment from the current network to the visited network. During this process, the MN will be provided with a new IP address from the new network and packets sent by a Correspondent Node (CN) to the MN will be lost. To overcome this problem, Mobile IPv4 (MIPv4) deploys an additional component called home agent on the home network that forwards the packet destined to the MN through a foreign agent on the visited network. This solution guarantees a correspondent host transparency but induces a high latency for addresses resolution and registration with the home agent. In addition, this mechanism, due to the triangular routing Anamalamudi *et al.* (2012) causes a high level of signalling flows over the core network. Thereby we observe long handover latencies with performance degradation for many applications. Mobile IPv6 (MIPv6) is an enhanced version of MIPv4. It uses the new mechanism introduced by IPv6 protocol for neighbouring networks discovery, movement detection and configuring a new address automatically on the visited network Pieterse *et al.* (2012). MIPv6 improves the handover latencies but it remains above 150ms which is the maximum acceptable value for real time multimedia applications as defined by the International Telecommunication Union (ITU TG-114). Hierarchical Mobile IPv6 (HMIPv6) Moravejosharieh, *et al.* (2012) was proposed to improve the performance of MIPv6 by dividing the overall networks into hierarchical domains. This structure reduces the signalling overhead and the registration delay between the MN and the CN thus improving the handover latencies. FMIPv6 Tran *et al.* (2011) is another protocol designed to reduce the movement detection phase time, the address auto configuration phase and the packet loss ratio. Section 7 of this paper will describe in details each of the protocols cited above.

Mobile Stream Control Transmission Protocol (mSCTP) is another protocol used for handover and is located at transport layer with TCP and UDP. mSCTP supports multi-homing and multi-streaming. Section 8 of this paper discusses this protocol and studies the corresponding handover latency in detail. Many research papers propose an improvement for handover latency with mSCTP. (Jin *et al.* 2011) use Mobile IP for location management of a MN which facilitates the SCTP association between a MN and a CN. They show, by experiment, that the proposed handover control schema gives better performance than the mobile SCTP protocol (mSCTP). Kim *et al.* (2008) show, through the performed experiments, that the handover latency with mSCTP is lesser than MIPv6 in heterogeneous environment. Lee *et al.* (2007) propose a new schema of mSCTP usage that improves the handover latency by 54% and the signalling cost by 45% compared to FMIPv6.

Session Initiation Protocol (SIP) is an IETF protocol for VoIP and multimedia session widely used in the handover at the application layer Boulahia *et al.* (2013) that will be described in detail in section 9. Many enhanced mechanisms for SIP handover exist in the literature. Ong *et al.* (2009) use SIP over IPv6 to manage the handover process when a MN performs inter domain mobility, namely macro-mobility management. They prove that the proposed SIP hybrid IPv6 decreases the unnecessary load and handover latency. Ong *et al.* (2005) experimented the integration of SIP and MIPv6 protocols for ad hoc networks and showed that the proposed mechanism is more efficient in terms of handover probability, triangle routing delay, throughput, and response time than existing wireless LAN systems with MIPv4. In (Thikrait *et al.* 2006), W. K. Chiang *et al.* proposed a new handover schema with SIP (SIPHO) based on the concept of Media Independent Handover (MIH) in order to enhance the handover performance of SIP. This new mechanism uses the lower layer intelligent trigger of MIH for handover detection and decision. W.K.Chiang *et al.* (2012) propose an enhancement of the Media-Independent Pre-Authentication (MPA) phase for handover by adding a redirect tunnelling (MPA-RT) Ed *et al.* (2011) in order to minimize handover delay and to prevent packet loss. Moreover, a seamless cross-layer SIP handover framework based on SIP, MPA-RT and Media Independent handover (MIH) is proposed. Kim *et al.* (2011) calculated the handover latency and signalling cost for SIP interworking with MIP schema and propose a new method for handover by using the Candidate Access Router Discovery mechanism (CARD). This protocol is designed for use in wireless IP networks to dynamically collect information about neighbouring access routers and their capabilities. This capability enables the MN to dynamically execute low-latency handover and to intelligently select a target access router Liebsch *et al.* (2005). Zeadally *et al.* (2007) experimented with lower packet transmission delay for SIP and SCTP as compared to Mobile IP.

### 3. Handover and Standardization Organizations

Vertical handover between different access networks is an important requirement to provide a QoS guarantee in a heterogeneous environment. Handover must be seamless for the user and this requires cooperation between different network technologies. Several approaches for standardization have been proposed by different bodies.

#### 3.1 IETF Standards

Various working groups of the Internet Engineering Task Force (IETF) provide enhanced versions of existing protocols that guarantee interoperability between different types of networks. This interoperability covers authentication, security, Quality of Service (QoS) and IP mobility management. In order to improve and optimize IP mobility, several IETF standards have been proposed such as Mobile IPv4 (MIPv4) Perkins *et al.* (2002), IPv6, Mobile IPv6 (MIPv6) Johnson *et al.* (2004), Fast Handover for Mobile IPv6 (FMIPv6) Koodli *et al.* (2008), Hierarchical Mobile IPv6 (HMIPv6) Soliman *et al.* (2005), Proxy Mobile IPv6 (PMIPv6), Multiple Care-of Addresses (MCoA), Dual Stack Mobile IPv6 (DSMIPv6) Soliman *et al.* (2009).

#### 3.2 3GPP Standards

Third Generation Partnership Project (3GPP) is an organization that aims to standardize the communication between cellular networks. This includes GSM (2G) Lagrange *et al.* (2006), UMTS (3G) and its various developments Sanchez *et al.* (2007) and LTE (4G) Lescuyer *et al.* (2008). 3GPP specifications and products offer a convergence solution between these cellular networks. In addition, other 3GPP working groups like TSG

SA1 standardize the communication between 3GPP and non-3GPP networks such as WI-FI and WIMAX. 3GPP (2006). The core network of LTE named Evolved Packet Core (EPC) is the latest evolution of the 3GPP core network architecture ETSI TS 124 312 V9.1.0. EPC contains the Access Network Discovery and Selection Function (ANDSF). ANDSF implements the handover management process and allows vertical mobility between 3GPP legacy systems and non-3GPP systems (3GPP TS 23.402). It also manages packet routing, transfer function, mobility and security management (3GPP TS 22.278).

#### **4. Different Types of Handover**

Handover is a key process in heterogeneous environments that offer QoS guarantee to the mobile user. Handover is divided into three phases: initiation, decision and execution. Handover could be performed according to one of the many schemas. Handover can also be horizontal between cells within the same technology or vertical between different types of radio access network. When a mobile node disconnects from the serving network and before connecting to the destination network, the handover is called hard handover or break before make handover. If the mobile node connects to the destination network before leaving the serving one, the handover is called soft handover or make before break handover.

##### *4.1 Mobile Controlled Handover Decision (MCHO)*

According to this schema, the MN takes the decision for handover based on existing local information such as Radio Signal Strength (RSS), Signal to Noise Interference Ratio (SINR), Blocking Error Rate (BLER), user preferences, mobile speed and others. The mobile controlled handover can be network-assisted (NAHO) where the network provides values concerning QoS parameters of a given network to the MN such as bandwidth and packet loss ratio. These parameters help the MN with making HO decisions (e.g.: in the case of the MIIS server within the MIH) (IEEE Std 802.21TM, 2009).

##### *4.2 Network Controlled Handover Decision (NCHO)*

In this mode, the network makes the decision for handover. Here, the handover can be mobile initiated or mobile assisted. In the former mode, the mobile node detects the presence of a new access point and estimates that there is a better network (handover initiation), it informs the network that allows or rejects the handover. In the latter mode, the network initiates the handover but the mobile assists this process (MAHO) by providing measurements of the environment that aid the network to make the best decision.

#### **5. Handover Process**

Regardless of the reasons behind the need for a mobile node to make a handover, an accurate vertical handover between different types of networks must be seamless to the user. Vertical handover process should not generate long latency or high packet loss ratio to guarantee QoS for real time applications. To meet this challenge, the handover process is accomplished through three phases. Figure 1 shows the handover process phases.

##### *5.1 Phase I: Handover Initiation and Network Information Gathering*

The handover process must start when a client node needs to leave its current point of attachment and connects to a better one. Usually, it is due to the value of the radio link quality or the QoS parameters that decrease below a certain predefined threshold. During this phase, the mobile node scans continually its vicinity to collect information about all visible networks. This kind of information is mandatory for the handover selection phase. Some of this information is network related like bandwidth, packet loss, network coverage, load, Bit Error Rate

(BER), Signal to Interference Ratio (SINR), security, etc. Other information is mobile related like Radio Signal Strength Indicator (RSSI), the battery strength and mobile speed. Finally, parameters like cost and QoS level can be user preferences related.

5.2 Phase II: Network Selection

During this phase, the information gathered from the previous phase will be compiled and a decision about the destination network will be validated. Time when the handover must be triggered is crucial for QoS guarantee for mobile applications. The handover algorithm of the standard does not implement the best decision mechanism. In the literature, many researches propose different ways to make this decision that we can classified, into two main categories: algorithm based decision and fuzzy logic based decision as depicted in Figure 1.

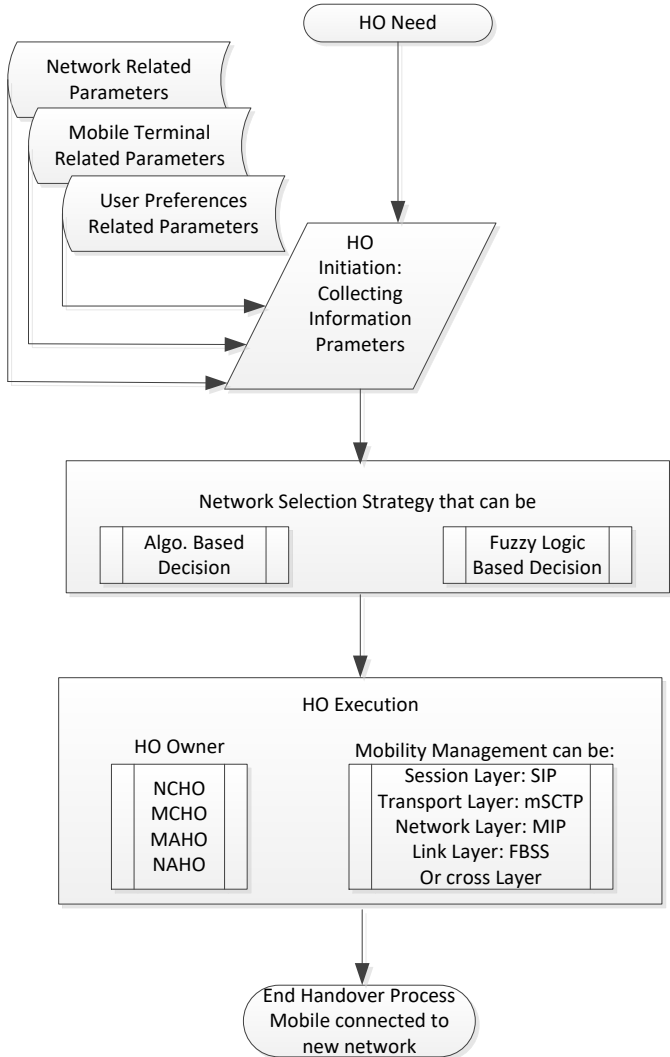

Figure 1. Handover Process Phases

5.3 Phase III: Handover Execution

Handover execution, as will be further explained in section 6, can be at different layers of the protocol stack. One of the most important challenges for this phase is to perform a seamless session transition process. One of the

four following schemas can be used for handover execution: NCHO usually adopted by operators for load balancing, MCHO, MAHO and NAHO.

## 6. Handover Layers

A key requirement of seamless handover management is to maintain the connection between both participants (endpoints). This can be carried out at different layers of the protocol stack. Depending on which layer the HO is taking place, some information becomes more crucial than others. Each layer of the protocol stack model has a specific HO protocol. Table 1 shows examples of protocols that can be used for each layer. It is important to notice that there is no relationship between the layer level in which the handover occurred and the time needed to accomplish this process. During handover, the MN takes a period of time (T) to change its point of attachment and packets sent between the MN and the correspondent node during this time are delayed or lost. The bigger the value of T is, the higher the packet loss ratio is. Many factors influence the value of T. These factors will be discussed in detail in the next sections.

Table 1. Handover Layers and Associated protocols

<b>Protocol Used For HO</b>	<b>Layer Level</b>	<b>Relevant Parameters Sharma et al. (2010)</b>
Session Initiation Protocol (SIP)	Application Layer Handley <i>et al.</i> (1999)	User Preferences Security Alert Context Information QoS Parameters
Stream Control Transmission Protocol (SCTP)	Transport Layer Aydin <i>et al.</i> (2003)	Network Load Network Topology and Routing Information
Mobile IP and all its variants (MIPv4, MIPv6, FMIPv6, HMIPv6)	Network Layer Perkins <i>et al.</i> (1997)	Available Foreign Agent Network Configuration and Pre-authentication
Fast Base Station Switching (FBSS)	Link Layer Agrawal <i>et al.</i> (2005)	Link Status Link Parameters Radio Network Access Condition
Cross-Layer	Can be at different layers Lin <i>et al.</i> , (2008)	
Media Independent Handover (MIH)	Between Link Layer and Network Layer Lampropoulos et al.	RSSI Mac parameters

	(2008)	Other parameters that can be retrieved from different service of MIH like MIES, MICS and MIIS.
--	--------	--

## 7. Handover Latency study

To better understand the causes of Handover Latency (HOL) and packet loss during handover, a detailed description of handover mechanisms used by different protocols is provided. Next, we give an empirical comparison for handover latency between MIPv4, MIPv6, HMIPv6 and FMIPv6. Then, in section 8 and 9, we study the HOL with mSCTP and SIP protocols.

### 7.1 Handover Latency Comparisons for MIPv4, MIPv6, HMIPv6 and FMIPv6 Mobility Protocol

Despite its large limitations, Internet Protocol (IPv4) is the base of abundant emerging applications today. IPv6 is an improvement version of IPv4 that offers largest range of IP addresses and is able to detect movement, discover neighbor networks and configure address automatically. Several working group within the IETF provide different version for the two flavors of Internet Protocol: IPv4 and IPv6. The research work that has been done to solve the problem of mobility in IP networks have led to two main categories: macro and micro-mobility as shown in Figure 2. The macro-mobility is mainly concerned with the transition of the MN between two different networks. Mobile IPv4 was designed to handle this type of mobility. We talk about micro mobility when the MN moves between two attachment points within the same network. FMIPv6 and HMIPv6 are considered as protocols that manage the micro-mobility.

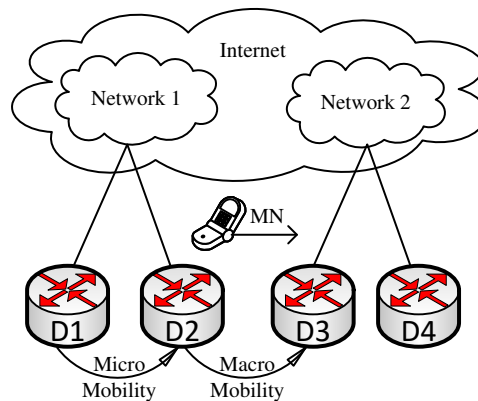

Figure 2. Macro and Micro-Mobility

During handover, the mobile device cannot receive or send any data because of link switching delay and IP protocol operation. This is called the handover latency (HOL) Datta et al. (2012). Handover latency is the primary cause of the packet loss and service deterioration. The lesser the HOL is, the better the QoS is. This delay is the sum-up of two times  $T_1$  and  $T_2$ .  $T_1$  is the time needed for a mobile node to disconnect from the serving network and reconnect to the destination network. Practically this time is consumed by Layer 2 reconnection process on the destination network and the signaling associated to this process ( $T_{L2Reconnection}$ ).  $T_2$  is the time due to the packets routing path during transfer (TPRP).

### 7.2 Handover Latency with MIPv4

According to MIPv4 schema, the packets sent by the correspondent node are intercepted by the home agent and then tunneled to the mobile. According to this schema, the mobile sends packets directly to the correspondent



node (triangular routing) Perkins *et al.* (2001). Triangular routing, depicted in Figure 3, introduces more signaling on the core networks which leads to a non-negligible period of HOL and increases the packet transfer delay.

With Mobile IPv4 (MIPv4), time due to the L2 reconnection process  $(T_{L2Reconnection})_{MIPv4}$  is the summation of the time needed by the MN to detect the new network  $(T_{DNN})_{MIPv4}$ , the time needed to obtain the new care of address  $(T_{NCoA})_{MIPv4}$  and the time needed by the MN for registering his new care of address (CoA) with its home network (HA)  $(T_R)_{MIPv4}$ . This latter is equal to the round trip time and depends on the distance between the MN and the HA.

$$(T_{L2Reconnection})_{MIPv4} = (T_{DNN})_{MIPv4} + (T_{NCoA})_{MIPv4} + (T_R)_{MIPv4}$$

During this time, packets sent from the correspondent node to the MN will be dropped or delayed.

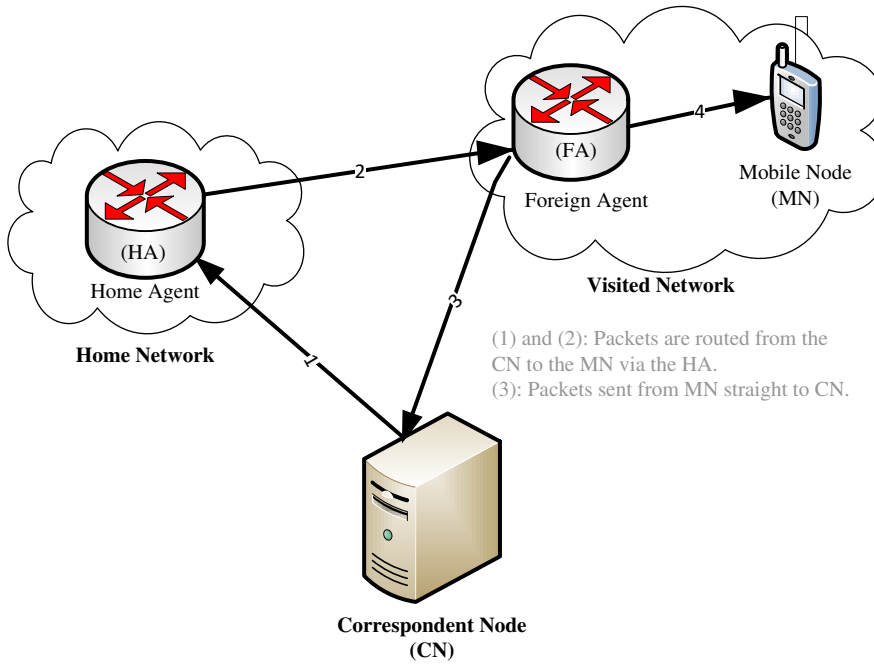

Figure 3. Packet Routing Path with MIPv4

With MIPv4, packet routing path time caused by the triangular routing path is given by:

$$(T_{PRP})_{MIPv4} = (T_{CN \rightarrow HA})_{MIPv4} + (T_{HA \rightarrow FA})_{MIPv4} + (T_{air})_{MIPv4} + (T_{FA \rightarrow MN})_{MIPv4}$$

Where  $(T_{CN \rightarrow HA})_{MIPv4}$  is the time needed for the packet transfer from the correspondent node to the home agent;  $(T_{HA \rightarrow FA})_{MIPv4}$  is the time needed for packet transfer from the home agent to the foreign agent,  $(T_{air})_{MIPv4}$  is the average time needed for the transfer over the air interface and  $(T_{FA \rightarrow MN})_{MIPv4}$  is the time needed for packet transfer from the FA to the MN.

This protocol suffers from a high handover latency, caused by the triangular routing, that is non-acceptable for many applications.

### 7.3 Handover Latency with MIPv6

To improve the handover latency, Mobile IPv6 (MIPv6) uses the mechanism provided by the IPv6 protocol for movement detection, neighbor discovery and auto address configuration Johnson et al.(2004). MIPv6 eliminates the need for a foreign agent of MIPv4 and provides a solution for the triangular routing problem by allowing a direct communication between the CN and the mobile node on the visited network. MIPv6 protocol exists in two modes: Bidirectional Tunneling Mode and Route Optimization Mode. According to the former mode, the CN does not require MIPv6 support and all traffic between CN and MN goes via the home agent. According to the latter mode, the MN requires registering its current binding at the CN and communication will be direct between MN and CN in both ways as shown in Figure 4. According to the Route Optimization Mode, the time needed to connect to a new network is given by the following formula:

$$(T_{L2Reconnection})_{MIPv6} = (T_{DNN})_{MIPv6} + (T_{NCoA})_{MIPv6} + (T_R)_{MIPv6}$$

MIPv6 has the capabilities to detect its neighbors, auto configure automatically the new care of address and eliminates the need of foreign agent then:

$$\begin{aligned} (T_{NCoA})_{MIPv6} &< (T_{NCoA})_{MIPv4} \\ (T_{DNN})_{MIPv6} &< (T_{DNN})_{MIPv4} \\ (T_{FA \rightarrow MN})_{MIPv6} &= 0 \end{aligned}$$

As a result, with MIPv6 the time needed for the L2 Disconnection from the old network and reconnection to the new network process is lesser than that with MIPv4.

$$(T_{L2Reconnection})_{MIPv6} < (T_{L2Reconnection})_{MIPv4}$$

As shown in Figure 2, the mobile device uses the Binding Update (BU) message to register its new temporary address with its home agent and all of its correspondents. So after receipt of the new address by the correspondent, it starts sending packets directly to the current location of the mobile without using the home agent. In this case, the  $(T_{PRP})_{MIPv6}$  is less than  $(T_{PRP})_{MIPv4}$  and can be evaluated by the following formula:

$$(T_{PRP})_{MIPv6} = (T_{CN \rightarrow MN})_{MIPv6} + (T_{air})_{MIPv6}$$

Where  $(T_{CN \rightarrow MN})_{MIPv6}$  is the time needed for packet transfer from the correspondent node to the mobile node and  $(T_{air})_{MIPv6}$  is the average time needed for the transfer over the air interface. Saving by that the time needed for the packet transfer from the correspondent node to the home agent of MIPv4  $(T_{CN \rightarrow HA})_{MIPv4}$  and the time needed for the packet transfer from the foreign agent to the mobile node  $(T_{FA \rightarrow MN})_{MIPv4}$ . The weakness of this protocol is that the MN must register with multiple entities (e.g. HA and all other correspondents) which increases the signaling over the core network and reduces the availability of the resources. Also, the delay taken by the auto configuration procedure is not negligible and is still not acceptable and above the minimum required (50 ms) by the ITU (International Telecom Union) to avoid

jitter in VoIP applications (ITU-TG.114, 1988).

#### 7.4 Handover Latency with HMIPv6

The Hierarchical Mobile IPv6 (HMIPv6) has come to solve the problems of MIPv6 for signaling overhead and to reduce the registration delay between MN and CN. To achieve its goal, the HMIPv6 divided the overall network into different hierarchical domains and introduces entities Soliman et al. (2008):. Access Router (AR) is the default gateway of the mobile node. Mobility Anchor Point (MAP) is a router that is used to introduce hierarchical levels. It plays the role of home agent for the mobile node inside the same subnet domain. Regional Care-of-Address (RCoA) is the address obtained by the MN in the visited network. This address is obtained automatically by auto configuration and is valid throughout the subnet managed by the same given MAP. On-Link Care-of-Address (LCoA) is the address that changes for each movement of the MN from one access point to another within the same domain managed by a given MAP.

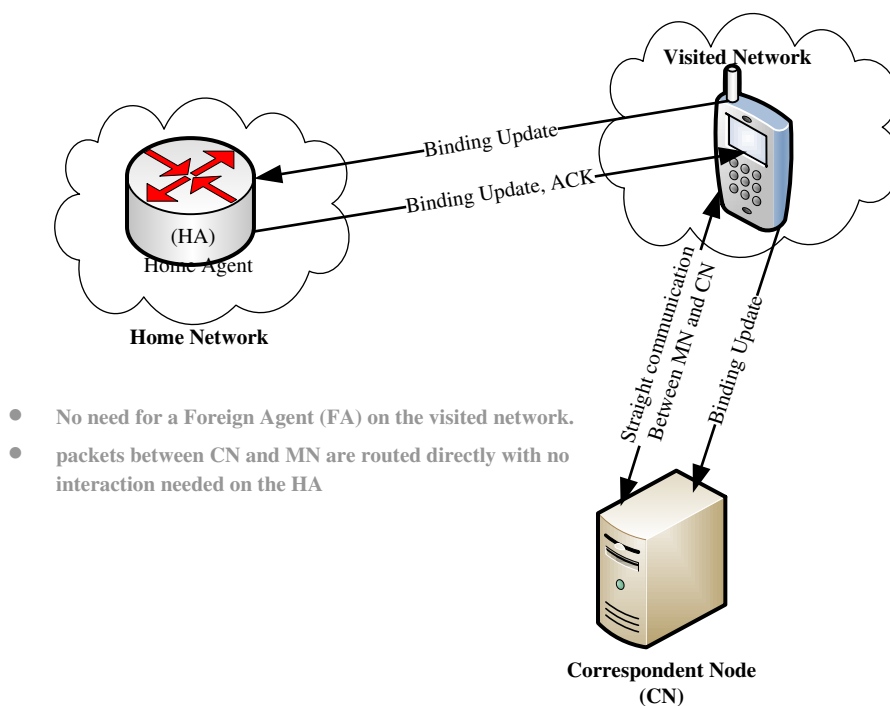

Figure 4. Packet Routing Path with MIPv6 (Route Optimization mode)

As shown in Figure 5, a mobile node that changes its point of attachment between AP1 and AP2, (micro-mobility within the same MAP domain), gets a new LCoA address while its RCoA address remains the same. In this case, the MN does not need to send the binding updates message to the home agent and the CN which improves the signaling overhead over the core network. For the case of inter-MAP domain handover (macro-mobility), the MN sends a BU message to the home agent and the CN. Then, it induces the same overhead signaling as MIPv6.

Due to the hierarchical structure of HMIPv6 protocol, the handover latency for an inter-map domain is equal to the HOL with MIPv6. The studied handover latency here is for the case of intra-MAP domain (micro mobility). With this schema, the MAP agent plays the role of home agent and is closer than the correspondent to the mobile node. This means that the round trip time needed by the mobile node for the

registration phase with the MAP  $(TR)_{HMIPv6}$ , acting as a home agent, is smaller in HMIPv6 comparatively to MIPv6 which improves the L2 reconnection delay during handover and reduces the signalling overhead.

### 7.5 Handover Latency with FMIPv6

Fast Handover Protocol for Mobile IPv6 is another extension of Mobile IPv6 designed to reduce the time of the movement detection phase, the address auto configuration phase and the packet loss. To achieve its goal, the FMIPv6 protocol defines the following messages Koodli et al. (2009):

Router Solicitation for Proxy Advertisement – RtSolPr: sent by the MN to the Previous Access Router (PAR) to request information about a potential handover. Proxy Router Advertisement – PrRtAdv: sent by the PAR to the MN providing information about the neighboring networks. Fast Binding Update – FBU: sent by the MN to the PAR. Its purpose is to allow the PAR to bind the previous temporary address (Previous Care-of Address -PCoA) to the new temporary address (Next Care-of Address -NCoA) and redirect packets destined to the previous temporary address (PCoA) to its new temporary address (NCoA). Fast Binding Acknowledgement – FBack: sent by the PAR to the MN and the New Access Router (NAR) to indicate the creation of a communication tunnel. Handover Initiate – HI: sent by the PAR to the NAR helping the handover of MN. Handover Acknowledge – Hack: sent by the NAR to the PAR as a reply message to the HI message. Fast Neighbor Advertisement – FNA: sent by the MN to the NAR to announce the attachment on this network.

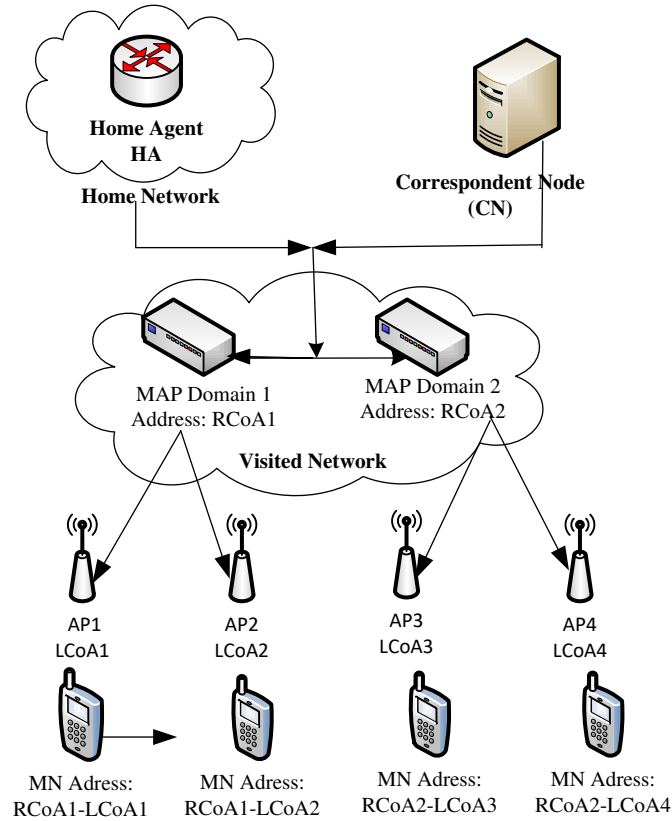

Figure 5. Packet Routing Path with HMIPv6

$$(T_{L2Reconnection})_{HMIPv6} = (T_{DNN})_{HMIPv6} + (T_{NCoA})_{HMIPv6} + (T_R)_{HMIPv6}$$

$$\text{Or } (T_R)_{\text{HMIPv6}} < (T_R)_{\text{MIPv6}}$$

$$\text{Then } (T_{L2\text{Reconnection}})_{\text{HMIPv6}} < (T_{L2\text{Reconnection}})_{\text{MIPv6}}$$

With this schema, the  $(T_{\text{PRP}})_{\text{HMIPv6}}$  remains equal to the  $(T_{\text{PRP}})_{\text{MIPv6}}$  and can be evaluated by the following formula:

$$(T_{\text{PRP}})_{\text{MIPv6}} = (T_{\text{CN} \rightarrow \text{MN}})_{\text{MIPv6}} + (T_{\text{air}})_{\text{MIPv6}}$$

Figure 6 shows the chronological steps to accomplish the handover process with FMIPv6. (1) MN receives a beacon message from the PAR; detection of the new network. (2) MN sends RtSolPr to the PAR with link layer address of the NAR. (3) The PAR sends a PrRtAdv message to the MN containing the subnet information. (4) MN sends a Fast Binding Update message containing the new CoA to the PAR. (5) Confirmation message of successful binding (FBack). (6) Tunnel creation between PAR and NAR to save packet loss. (7) Handover Initiation message (HI) to indicate that the MN is going to initiate the handover. (8) Handover acknowledgement (HACK) to confirm that the NAR is ready to accept the connection with the MN. (9) Fast Neighbor Advertisement (FNA) message announcing the attachment of MN to the NAR and Initiation of packet flows between MN and the PAR.

FMIPv6 handover exists in two modes: Predictive and Reactive. With the predictive mode, the MN sends the FBU message before connecting to the NAR while with the reactive mode; the MN needs to be attached to the NAR before being able to send the FBU Gelogo et al. (2012). Reactive handover happens when the MN is not able to predict the handover because of sudden drop/loss of signal from its attached access point. Predictive handover is performed when a MN is able to anticipate a handover. This predication is triggered when the signal strength of an associated link drops below a certain threshold.

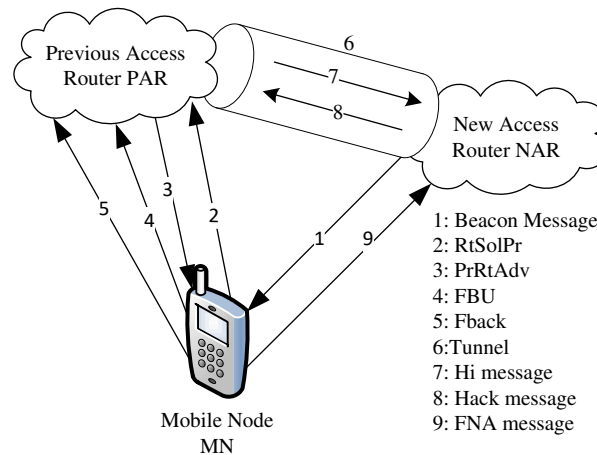

Figure 6. Packet Routing Path with FMIPv6

FMIPv6 protocol aims to deeply reduce the delay of the auto-address configuration phase by configuring the new care of address (NCoA) of the mobile node before it starts to move from its current point of attachment (PAR). In fact, when an MN detects a new access router, a new link is established prior moving to it. Then, the period of auto-address configuration phase is deeply reduced comparatively to the HMIPv6 protocol and can be

neglected. Also, by using the PrRtAdv and FBU messages the  $(T_{DNN})_{FMIPv6}$  is lesser than the  $(T_{DNN})_{HMIPv6}$ . According to this schema, the L2 reconnection delay during handover is given by:

$$\begin{aligned} (T_{L2Reconnection})_{FMIPv6} &= (T_{DNN})_{FMIPv6} + (T_{NCoA})_{FMIPv6} + (T_R)_{FMIPv6} \\ &\text{Or } (T_{NCoA})_{FMIPv6} < (T_{NCoA})_{HMIPv6} \\ &\text{And } (T_{DNN})_{FMIPv6} < (T_{DNN})_{HMIPv6} \\ &\text{Then } (T_{L2Reconnection})_{FMIPv6} < (T_{L2Reconnection})_{HMIPv6} \end{aligned}$$

The  $(T_{PRP})_{FMIPv6}$  remains equal to the  $(T_{PRP})_{HMIPv6}$  and can be evaluated by the following formula:

$$(T_{PRP})_{FMIPv6} = (T_{CN \rightarrow MN})_{FMIPv6} + (T_{air})_{FMIPv6}$$

As a consequence, the handover latency will be improved. Also, the packet loss ratio will be improved thanks to the tunneling mechanism. Table 2 summarizes the handover latency for the discussed IP based protocols.

## 8. Handover with SCTP Protocol

Stream Control Transmission Protocol (SCTP) is located at transport layer with TCP and UDP. In addition to the TCP features, SCTP, standardized by the Transport Area Working Group (TSVWG) of the IETF, supports multi-homing Riegel et al. (2002), multi-streaming Fu et al. (2004) and is message-oriented. Multi-streaming consists of delivering independent data streams. Multi-homing allows the SCTP node to be reached through multiple IP addresses. During the establishment of an SCTP association between two endpoints Stewart et al. (2007), one primary path is defined for data transfer and one or more secondary paths are also defined and used for signalling, retransmission or as recovery path in case of failure of the primary path as shown in Figure 7. To do this association, SCTP defines the following methods: INIT (initiate the association), INIT ACK (confirm the initiation of the association by the receiver endpoint), COOKIE ECHO (to finalize the association initiation) and COOKIE ACK (sent by the receiver endpoint as an answer to the COOKIE ACK). Data transfer between two endpoints is done through the Chunk DATA. As a response to Chunk DATA, the receiver endpoint sends the SACK chunk. At the end, the association is released properly by a SHUTDOWN chunk or abruptly by an ABORT chunk Stewart et al. (2007). In order to support seamless vertical handover, mobile SCTP (mSCTP) adds the Dynamic Address Reconfiguration (DAR) (Stewart et al. 2006) and the ADDIP extension that enables SCTP nodes to dynamically add, delete and modify their primary address without terminating the ongoing association. Then the MN, during handover, gets a new IP address on the visited network, With the Dynamic Address Reconfiguration (DAR) procedure (Stewart et al.2007) and switches its primary path from the old IP address to a new IP address seamlessly Koh et al. (2004).

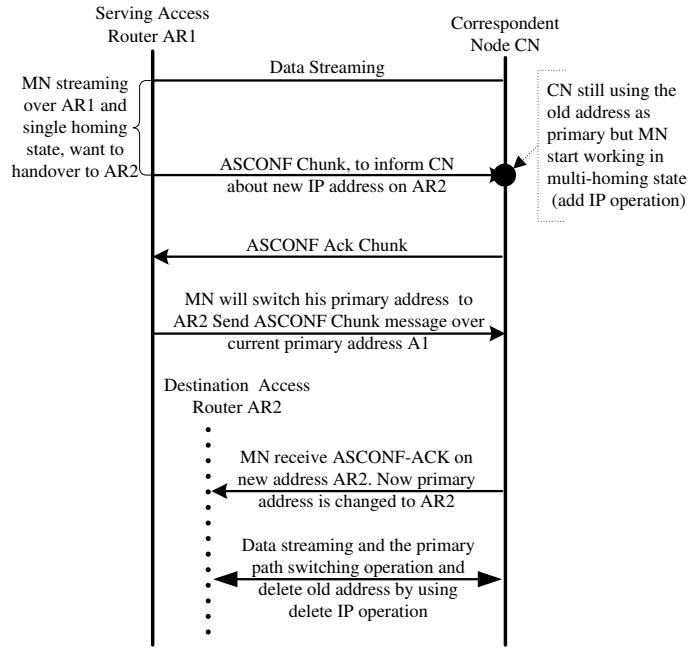

Figure 7. Handover Flow Chart with mSCTP.

Table 2. Handover Latency Comparison between: MIPv4, MIPv6, HMIPv6 and FMIPv6

	MIPv4	MIPv6	HMIPv6	FMIPv6
<b>T<sub>L2Reconnection</sub></b> <b>(T<sub>1</sub>)</b>		$(T_{DNN})_{MIPv6} <$	$(T_{DNN})_{HMIPv6} =$	$(T_{DNN})_{FMIPv6} <$
	$(T_{DNN})_{MIPv4}$	$(T_{DNN})_{MIPv4}$	$(T_{DNN})_{MIPv6}$	$(T_{DNN})_{HMIPv6}$
	+	+	+	+
	$(T_{NCoA})_{MIPv4}$	$(T_{NCoA})_{MIPv6} <$	$(T_{NCoA})_{HMIPv6} =$	$(T_{NCoA})_{FMIPv6} <$
	+	$(T_{NCoA})_{MIPv4}$	$(T_{NCoA})_{MIPv6}$	$(T_{NCoA})_{HMIPv6}$
	$(T_R)_{MIPv4}$	+	+	+
		$(T_R)_{MIPv6} = (T_R)_{MIPv4}$	$(T_R)_{HMIPv6} < (T_R)_{MIPv6}$	$(T_R)_{FMIPv6} =$
				$(T_R)_{HMIPv6}$

		0	0	0
		+	+	+
	$(T_{CN \rightarrow HA})_{MIPv4}$	$(T_{CN \rightarrow MN})_{MIPv6} <$	$(T_{CN \rightarrow MN})_{HMIPv6} =$	$(T_{CN \rightarrow MN})_{FMIPv6} =$
	+	$(T_{CN \rightarrow HA})_{MIPv4} +$	$(T_{CN \rightarrow MN})_{MIPv6}$	$(T_{CN \rightarrow MN})_{HMIPv6}$
	$(T_{HA \rightarrow FA})_{MIPv4}$	$(T_{HA \rightarrow FA})_{MIPv4}$	+	+
	+	+	+	+
	$(T_{air})_{MIPv4}$	$(T_{air})_{MIPv6} =$	$(T_{air})_{HMIPv6} =$	$(T_{air})_{FMIPv6} =$
	+	$(T_{air})_{MIPv4}$	$(T_{air})_{MIPv6}$	$(T_{air})_{HMIPv6}$
	$(T_{FA \rightarrow MN})_{MIPv4}$	+		
		0		
<b>Signaling Level</b>	Very High	Average	Low	Low
<b>Handover latency (HOL)</b>	$(HOL)_{MIPv4} =$	$(HOL)_{MIPv6} =$	$(HOL)_{HMIPv6} =$	$(HOL)_{FMIPv6} =$
	$(T_{L2Reconnection})_{MIPv4}$	$(T_{L2Reconnection})_{MIPv6}$	$(T_{L2Reconnection})_{HMIPv6}$	$(T_{L2Reconnection})_{FMIPv6}$
	+	+	+	+
	$(T_{PRP})_{MIPv4}$	$(T_{PRP})_{MIPv6}$	$(T_{PRP})_{HMIPv6}$	$(T_{PRP})_{FMIPv6}$
	+	+	+	+
	Signaling Level on MIPv4	Signaling Level on the core network with MIPv6	Signaling Level on the core network with HMIPv6	Signaling Level on the core network
<b>Handover latency</b>	$(HOL)_{MIPv4}$	$(HOL)_{MIPv6} <$	$(HOL)_{HMIPv6} <$	$(HOL)_{FMIPv6} <$
		$(HOL)_{MIPv4}$	$(HOL)_{MIPv6}$	$(HOL)_{HMIPv6}$
<b>PLR</b>	$(PLR)_{MIPv4}$	$(PLR)_{MIPv6} <$	$(PLR)_{HMIPv6} <$	$(PLR)_{FMIPv6} <$
		$(PLR)_{MIPv4}$	$(PLR)_{MIPv6}$	$(PLR)_{HMIPv6}$

### 9. Handover with SIP Protocol

Session Initiation Protocol (SIP) is an application layer protocol for establishing a multimedia session in peer-to-peer IP communication Kim et al. (2011). Users in an SIP environment are identified by their addresses (user@domain) that are mapped to their IP address Nakajima et al. (2003). To establish a SIP communication between two user agents, they must know the SIP address of each other. Networks running the SIP protocol define several logical entities namely: User Agent that is a SIP gateway between interlocutors, Proxy Server that acts as an intermediary between two user agents, Redirect Server is a server to redirect calls between user agents; and the Registrar element used by the user agent to specify within the REGISTER message the address where it can be reached (e.g., IP address). The Registrar then updates continually a database location to follow the mobility of the user agent Camarillo et al. (2002). SIP protocol, to establish communication between two hosts, define six basic methods shown in Table 3.

Table 3. SIP Methods

Method	Description
--------	-------------



ACK	Confirm a successful session establishment
BYE	Close an established session
CANCEL	Cancel a pending request
INVITE	Initiate a session or re-negotiate an ongoing session
OPTION	Request information about the capabilities of another UA or proxy server
REGISTE	Add, remove, or query the UA's address bindings in the location service
R	

SIP supports terminal, session, personal and service mobility. Terminal mobility allows a device to change its point of attachment while being reachable by incoming traffic. Heterogeneous handover with SIP is managed by one of the two terminal mobility schemas: pre-call mobility and mid-call mobility. With pre-call mobility schema, the MN moves to a different location and starts a new session while with mid-call mobility, the MN continues with the ongoing session while it changes its point of attachment. Handover latency will be studied here for the mid-call mobility schema. This handover latency is summing up of the time for a MN to disconnect from the current network and connect to the destination network (disconnection-connection)SIP and the time of packet routing path during handover (TPRP)SIP. (disconnection-connection)SIP is the same as the mobility protocol used at layer 3 (MIPv6, FMIPv6, HMIPv6). What makes the difference is the time of packet routing path during handover. As shown in Figure 8, this delay is due to the re-invite message and its confirmation.

$$(T_{PRP})_{SIP} = D_{re-invite} + D_{confirmation}$$

## 10. Handover with IEEE 802.21 Standards

User mobility can be achieved at different levels of the protocol stack. The IEEE802.21 standard, also known as Media Independent Handover (MIH), provides mobility management at layer 2.5, by being inserted between layer 2 and layer 3. As depicted in Figure 9, the Media Independent Handover Function (MIHF) is the main entity of the standard that allows communication in both directions between lower and upper layers through three services: event, command and information Rehan et al. (2009).

### 10.1 Media Independent Event Services, MIES

This service detects changes in the lower layers (physical and link) to determine if it needs to perform handover. Two types of events can occur: "MIH Event" sent by the MIHF to the upper layers (3 +), and "Link Event" that spreads from the lower layers (PHY, MAC) to the MIHF.

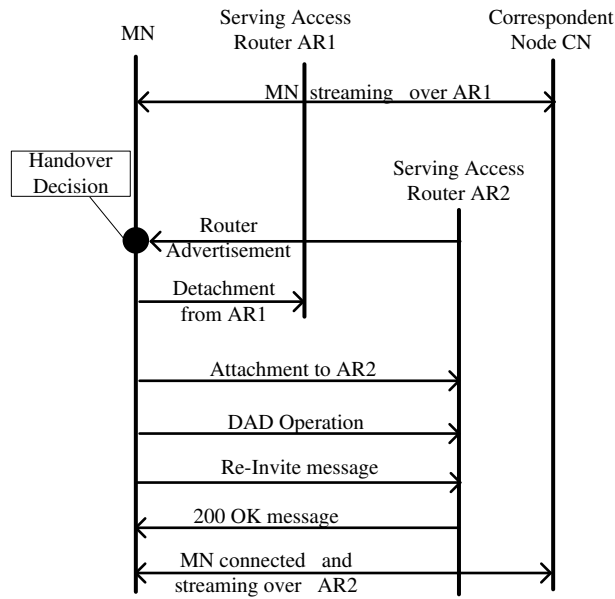

Figure 8. Handover Flow Chart with SIP

### 10.2 Media Independent Command Services, MICS

This service uses two types of events. The "MIH Commands" transmitted by the user towards the MIHF and "Link Commands" sent by MIHF to lower layers.

### 10.3 Media Independent Information Services, MIIS

The MIIS lets the mobile user discover and collect information about features and services offered by neighboring networks such as network type, operator ID, network ID, cost, and network QoS, etc. This information helps doing a more efficient handover decision across heterogeneous networks.

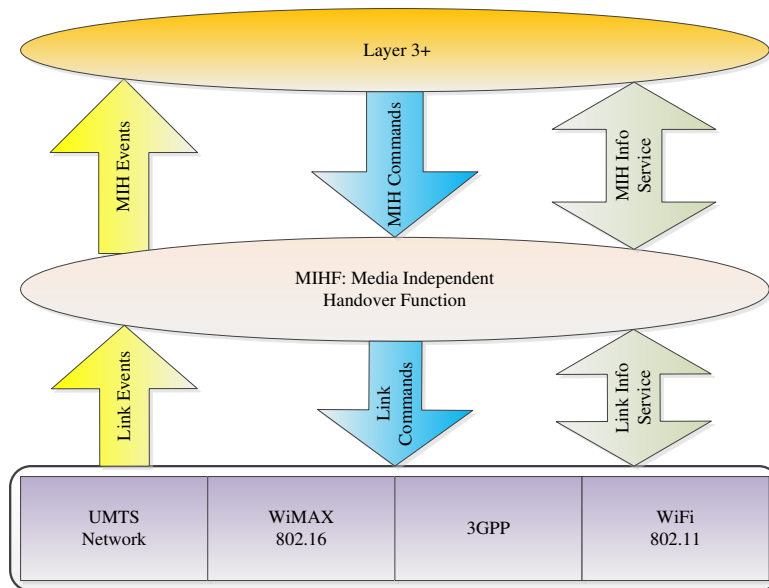

Figure 9. MIH architecture

## 11. Open research for minimizing handover latency

Numerous research papers proposed a solution for minimizing the handover latency caused with any of the protocols cited above. Kim et al. (2008) use MIH to improve the handover latency with FMIPv4. The use of MIH helps to get the position of the mobile and a list of the APs in the vicinity from the MIIS. Authors of this paper use their proper algorithm to select the best network and show an improvement in handover latency comparatively to the FMIPv4 process. Wei et al. (2007) proposes a new framework for handover, called E-HCF (Extended Handover Control Function) in the router side without changing any other network devices. When the MN needs to change its point of attachment, the E-HCF router proposes a list of potentially useful access points that are selected and ranked by a selection and classification algorithm. This improves the handover delay. In addition, during the handover process, the HA intercepts and keeps the packets destined to the home address of the MN in its buffer. These packets will be forwarded to the MN after handover process completion. Thereby, they reduce the number of packets lost during the handover. (Zhao et al. 2009) propose an improved handover scheme in heterogeneous mobile IPv6 environment with the support of MIH Services and an improved version of the DAD called A-DAD (Advance Duplicate Address Detection). By using MIH services, this scheme prepares another network interface for handover before the current interface is down. In addition, by using the A-DAD, the duplicate address detection time is deeply reduced; reducing by that handover latency as well as packet loss. Khan et al. (2011) use the Media Independent Information Server MIIS of MIH to improve the information discovery procedure of MIPv6 and reduce the handover delay with MIPv6 to a tolerable limit. Zhengzhou et al. (2010) uses the Context Transfer Protocol (CTP) to make the handover with FMIPv6 faster. By using the CTP, the MN can re-authenticate (AAA services) without intervention of the home network and this will improve the handover latency. Hsieh et al. (2002) compare the impact of L3 handover latency for various MIP architecture variants, MIPv6 FMIPv6 and HMIPv6. The authors show, through simulation, that fast handover mechanism alone is capable of reducing the handover latency and packet loss when compared to MIPv6. The hierarchical structure is also able of minimizing packet loss and handover latency compared with the MIPv6. They propose reducing the overall handover latency by 18 times compared with MIPv6 architecture by combining the hierarchical structure with fast handover (FMIPv6). Mussabbir et al. (2007) integrate MIH with FMIPv6 in order to use MIH triggers to provoke predictive FMIPv6 handovers. MIIS provides the MN with a mapping list of available PoAs (Access Point). This eliminates the Proxy Router Solicitation message as the initial step of the FMIPv6 handover process. Yoo et al. (2008) propose a new model that uses the MIIS to get the round trip delay between neighbour PoAs. This time, integrated in the new model, offers the handover time estimation. This allows the MNs to make more effective handover decisions in FMIPv6 network based on the neighbor networks information. Jeong, et al. (2011) introduce the concept of virtual layer where each MAPs in the same HMIPv6 domain have a virtual MAP (VMAP) and is related to it. This architecture reduces the signaling traffic for location updates. The performed experience shows that the proposed scheme reduces greatly the packet loss and the delay during handover. Liu et al. (2011) propose a new schema to select the most appropriate MAP called F-HMIPv6. This schema considers the load balancing, session arrival and the movement velocity of a MN during intra-inter MAP handover. Chen et al. (2011) identified three major reasons for the HMIPv6 handover delay: Movement Detection, Duplicate Address Detection (DAD), and Binding Update (BU), in which DAD occupy most of the HMIPv6 handover delay. To avoid this problem, they propose a new schema called Fast-Reconfigure Address Mechanism (F-RAM) to replace the DAD procedure and generate a quicker unique address. The experiments that they performed show that the proposed scheme reduces the handover delay and the packet loss. Zubairi et al. (2011) propose a new algorithm called CSH that uses a mixed version of SIP and HMIPv6 protocols. The proposed algorithm provides end-to-end service level guarantee thanks to less delay, seamless session and network mobility, bandwidth management, resources reservation, user authentication and

integrity. It will reduce the delay and the signaling overhead on core network.

Table 4. A comparative summary of open research on HOL improvement

Articles	Propositions	used Protocol	Using MIH	Allows	Results
(Kim et al. 2003)	Use MIHF to obtain the position of the mobile. Knowing the coordinates of the mobile, the MIHF gets a list of APs from MIIS.	FMIPv4	No	Allows choosing a list of APs while meeting two criteria: (1) distance between the MN and the AP. (2) a minimum of QoS level is required.	Choose the AP that provides the best QoS
(Wei et al. 2007)	Adds a new feature, called E-HCF (Extended Handover Control Function) in a router.	IPv6	Yes	Allows the router to generate a topology of access points using neighborhood graph theory and maintain a pool of available IP addresses.	Improves handover performance in terms of delay and reduces the packet loss during the handover.
(Zhao et al. 2009)	Propose an improved HO scheme with the support of MIH Services and an advanced version of Duplicate Address Detection	IPv6	Yes	Provides another network interface for HO before the current interface is down.	Reduces the handover latency and packet loss.
(Khan et al. 2011)	Propose an intelligent handover mechanism on MIPv6 handover delays, using MIH.	MIPv6	Yes	Provides shorten Duplicate Address Detection of MIPv6 by using the Media Information Server MIIS of MIH.	Improves the time of HO by 25%.
(Zhengzhou et al. 2011)	Uses the Context Transfer Protocol (CTP)	FMIPv6	No	The using of CTP eliminates the re-authentication phase (AAA) of the MN on the new network	Minimizing the time of handover and improving the ratio of packet loss.
(Hsieh et al. 2002)	Compare the impact of the layer-3 handover latency on end-to-end TCP stream for MIPv6 FMIPv6 and HMIPv6	HMIPv6 + FMIPv6	No	proposes combining solutions by mixing the hierarchical structure with fast handover	Reducing the overall handover latency by 18 times compared to MIPv6.
(Mussabbir et al. 2007)	Integrate MIH with FMIPv6 in order to use MIH triggers to provoke predictive FMIPv6 handovers.	FMIPv6	Yes	Provides the MN with mappings of PoAs addresses to IP addresses. Removing the Proxy Router Solicitation message from the handover process.	Decreases the signaling and reduces the time of the handover.
(Yoo et al. 2008)	Propose a new model for a predictive handover mechanism in heterogeneous wireless networks.	FMIPv6	Yes	Allowing MNs to make more effective handover decisions based on the neighbor network	Minimizing the handover latency and the service disruption time.
(Jeong, et al. 2011)	Introduce the concept of virtual layer where many MAPs in the same HMIPv6 domain have a virtual MAP (VMAP)	HMIPv6	No	The proposed architecture allows to reduce the signaling traffic for location updates	Reducing packet loss and handover delay.

(Gan et al. 2011)	Proposes a new schema to select the most appropriate MAP called F-HMIPv6.	HMIPv6	No	It allows taking care of the load balancing, session arrival and the movement velocity of the MN during handover.	Improvement of the QoS.
(Lee et al. 2011)	Proposes a new schema called Fast-Reconfigure Address Mechanism (F-RAM) to replace the old Duplicate Address Detection	HMIPv6	No	Allocation of a new care of address for a MN during handover is faster	Improves the handover latency.
(Zubairi et al. 2011)	Propose a new algorithm called CSH and based on mixed SIP and HMIPv6 protocols.	SIP + HMIPv6	No	Offers better end-to-end QoS, less delay, seamless session and network mobility, bandwidth management, resources reservation, user authentication and integrity.	Reduces the delay and signaling overhead on core network which will improve the handover latency.

## 12. Conclusion and Future Work

Handover is a complex process that involves several participants at different levels of the protocol stack. In this paper, we presented different standardization organizations research works enabling mobility within heterogeneous environments while discussing the different phases of the handover process. In addition, the Media Independent Handover standard (IEEE 802.21) for seamless handover in heterogeneous environment is described and its usage is detailed. During internetworking process, handover latency is a crucial parameter for QoS guarantee. For this reason, this paper, focused on studying and comparing the handover latency using different protocols such as MIPv4, MIPv6, HMIPv6 and FMIPv6. Finally, this paper provided an open research area where we have discussed different solutions proposed in the literature to improve the handover latency and thereby to guarantee a better QoS at different level of the protocol stack. Finally, by highlighting the pros and cons of each discussed protocol and showing the latencies introduced by the corresponding mechanisms, we hope that this could be helpful for future research works to provide enhanced mechanisms for mobility management in heterogeneous environments while minimizing handover delays to enable end-to-end QoS guarantee for real time applications.

## References

- Zekri M., Jouaber B. & D. Zeglache, (2012), "A review on mobility management and vertical handover solutions over heterogeneous wireless networks", *Computer Communications*, Volume 35, Issue 17, PP: 2055-2068,
- Yan X., Şekercioğlu Y. A. & Narayanan S., (2010), "A survey of vertical handover decision algorithms in Fourth Generation heterogeneous wireless networks", *Computer Networks*, Volume 54, Issue 11, PP: 1848-1863.
- Barja J. M., Calafate C. T., Cano J. C. & Manzoni P., (2011), "An overview of vertical handover techniques: Algorithms, protocols and tools", *Computer Communications*, Volume 34, Issue 8, PP: 985-997.
- Anamalamudi S., Xu W. & Liu X., (2012), "Performance Enhancement of TCP in Mobile IP based Networks", *Computer and Information Science (ICIS), IEEE/ACIS 11th International Conference on*, doi: 10.1109/ICIS.2012.84, PP: 88 – 93.
- Pieterse J. & Wolhuter R., (2012) "Investigation of Handover Techniques in a IPv6 Mobile Network", *IEEE-APWC Topical Conference on Antennas and Propagation in Wireless Communications*, doi: 10.1109/APWC.2012.6324985, PP: 1020 – 1023.
- Moravejosharieh A., Salleh R. & Modares H., (2012), "Overview of Handover Latency and Resource Consumption in Hierarchical Mobile IPv6 Protocol and GPS Approaches", *Intelligent Systems, Modelling and*

Simulation (ISMS), Third International Conference on, doi: 10.1109/ISMS.2012.10, PP: 579 – 583.

Tran C.H. & Duong V.T, (2011), “Mobile IPv6 Fast Handover Techniques”, Advanced Communication Technology (ICACT), 13th International Conference on, PP: 1304 – 1308.

Jin J., Zhang Q., Cui L. & Xuan Z., (2011), “mSCTP Vertical Handover in the Overlap of Heterogeneous Wireless Networks”, Seventh International Conference on (ICNC), doi: 10.1109/ICNC.2011.6022498, PP: 1537 – 1540.

Kim D. & Joo Koh S., (2008), “Analysis of Handover Latency for Mobile IPv6 and mSCTP”, Communications Workshops, ICC Workshops IEEE International Conference on, doi:10.1109/ICCW.2008.85, PP: 420 – 424.

Lee J.M., Lim H.J., Lee J. H., & T.M. Chung, (2007), “A Scheme to reduce the handoff latency using mSCTP in Fast Mobile IPv6”, Systems and Networks Communications ICSNC Second International Conference on, doi: 10.1109/ICSNC.2007.8, PP:14.

Ahmed, A. ; Boulahia, L. & Gaiti, D., (2013), “Enabling Vertical Handover Decisions in Heterogeneous Wireless Networks: A State-of-the-Art and A Classification”, Communications Surveys & Tutorials, IEEE, Vol PP, Issue: 99, PP: 1 – 36, doi: 10.1109/SURV.2013.082713.00141.

Siddiqui F., Zeadally S., El-Sayed H. & Chilamkurti N. (2009), “A dynamic network discovery and selection method for heterogeneous wireless networks” Int. J Internet Protocol Technology, doi: 10.1504/IJIPT.2009.027335 PP: 99-114,, vol.4.

Ong B. & Hassan S., (2005), “A Survey of IPv6 Mobility Management in Real-time Communications”, Malaysia International Conference on Communication, 13th IEEE International Conference on, doi: 10.1109/ICON.2005.1635643, PP: 929-934, vol 2.

Thikrait Al Mosawi, Dave Wisely & Hamid Aghvami, (2006), “A Novel Micro Mobility Solution Based on Media Independent Handover and SIP”, Vehicular Technology Conference, 2006. VTC-2006 Fall. 2006 IEEE 64th, doi: 10.1109/VTCF.2006.259, Page(s): 1 – 5.

Chiang W.K., Dai H.J. & C. Luo, (2012), “Cross-Layer Handover for SIP Applications based on Media-Independent Pre-Authentication with Redirect Tunneling”, Digital Information and Communication Technology and it's Applications (DICTAP), Second International Conference on, doi: 10.1109/DICTAP.2012.6215373, PP: 348 – 353,

Ed D., Fajardo V., Ohba Y., Taniuchi K., & H. Schulzrinne, (2011), “A framework of media-independent pre-authentication (MPA) for inter-domain handover optimization”, IETF RFC 6252, February.

Kim K.Y., Ham K.G., Cho K.S. & Choi S. G., (2011), “Seamless Handover Scheme based on SIP in Wireless LAN”, Advanced Communication Technology (ICACT), 13th International Conference on, PP: 847 – 851.

Liebsch M. & Singh A., (2005), "Candidate Access Router Discovery (CARD)", IETF, RFC 4066,.

Zeadally S., Siddiqui F., (2007), “An Empirical Analysis of Handoff Performance for SIP, Mobile IP, and SCTP Protocols”, Wireless Personal Communications, PP: 589-603 doi: 10.1007/s11277-007-9251.

Perkins C., (2002), “IP Mobility Support for IPv4. RFC 3344”, August. Updated by RFC 4721.

Johnson D., Perkins C., and J. Arkko. (2004), “Mobility Support in IPv6. RFC 3775”.

Koodli R., (2008), “Mobile IPv6 Fast Handovers RFC 5268”.

Soliman H., Castelluccia C., El Malki K., and Bellier L., “Hierarchical Mobile IPv6 Mobility Management (HMIPv6)”. RFC 4140, August 2005.

Soliman H., (2009), “Mobile IPv6 Support for Dual Stack Hosts and Routers”, RFC 5555.

Lagrange X., Godlewski P., & Tabbane S., (2006), “GSM GPRS : réseaux GSM”, Hermès - Lavoisier.

Sanchez J., and Thioune M., (2007), “UMTS releases 6, 7 et 8, HSUPA, MBMS et LTE/E-UTRA”, Hermès - Lavoisier,.

Lescuyer P. & Lucidarme T., (2008), "Evolved Packet System (EPS): the LTE and SAE evolution of 3G UMTS".

3GPP, (2003), "Feasibility study on 3GPP system to WLAN interworking", TR22.934 v6.2.0,

3GPP, (2006), "system to Wireless Local Area Network (WLAN) interworking; System description", TS 23.234 v7.2.0,.

ETSI TS 124 312 V9.1.0, "Universal Mobile Telecommunications System (UMTS); LTE; Access Network Discovery and Selection Function (ANDSF)".

3GPP TS 23.402, "Architecture Enhancements for non-3GPP accesses".

3GPP TS 22.278: "Service requirements for the Evolved Packet System (EPS)".

3GPP TS 23.402: "Architecture enhancements for non-3GPP accesses".

IEEE Std (2009), 802.21TM.

Handley M. et al, (1999), "Session Initiation Protocol", RFC 2543.

Aydin I. and Shen C., (2003), "Cellular SCTP: A Transport-Layer Approach to Internet Mobility", ICCCN, PP: 285-290.

Perkins C.E. & Myles A., (1997), "Mobile IP", IEEE Communications Magazine, doi:10.1109/35.592101, PP: 84-99, Volume: 35, Issue:5.

Agrawal A., (2005), "Air Interface for Fixed and Mobile Broadband Wireless Access Systems, Amendment 2: Physical and Medium Access Control Layers for Combined Fixed and Mobile Operation in Licensed Bands", IEEE802.16e.

Lin P., Lin T. & Wang C., (2008),"Performance Analysis of a Cross-Layer Handoff Ordering Scheme in Wireless Networks", IEEE Transactions on Wireless Communications, PP: 5166–5171 Vol.7, No. 12.

Chang B. & Chen J., (2008),"Cross-Layer-Based Adaptive Vertical Handoff with Predictive RSS in Heterogeneous Wireless Networks", IEEE Transactions on Vehicular Technology, PP: 3679-3692, vol. 57, No. 6.

Lampropoulos G. & Salkintzis A. K, (2008), "Media-Independent Handover -for Seamless Service Provision in Heterogeneous Networks", IEEE Communication Magazine, doi: 10.1109/MCOM.2008.4427232, PP: 64-71, vol: 46, Issue: 1.

Sharma M. & Khola R.K., (2010),"An Intelligent Approach for Handover Decision in Heterogeneous Wireless Environment", International Journal of Engineering (IJE),, pp 452-462, Vol. 4, No. 5.

Datta V., Gagneja A., Datta R. & Goel V., (2012), " A Comparative Handoff Latency Evaluation in IPv6 Based Mobility Management Protocols", International Journal of Applied Engineering Research, ISSN 0973-4562, vol.7 No.11.

Perkins C. (2010), "RFC 5944, IP Mobility Support for IPv4"

Johnson D., Perkins C., Arkko J., (2004), "RFC 3775, IP Mobility Support in IPv6".

International Telecommunication Union (ITU), (1988), "General Characteristics of International Telephone Connections and International Telephone Circuits", ITU-TG.114.

Soliman H., Castelluccia C., El Malki K. & Bellier L., (2008), "RFC 5380, Hierarchical Mobile IPv6 (HMIPv6) Mobility Management".

Koodli R., (2009), "RFC 5568, Mobile IPv6 Fast Handovers".

Gelogo Y. E. & Park B., (2012), "Reducing Packet Loss for Mobile IPv6 Fast Handover (FMIPv6)", International Journal of Software Engineering and Its Applications, PP: 87-92, vol. 6, No. 1.

Riegel M., Tuxen M., Rozic N., & Begusic D., (2002), "Mobile SCTP transport layer mobility management for the Internet" in Proc.SoftCOM, PP:305–309.

- Fu S. & Atiquzzaman M., (2004), "SCTP: State of the art in research, products, and technical challenges," IEEE Commun. Mag., PP: 64–76, vol. 42, no4.
- Stewart R., et al., (2007), "Stream Control Transmission Protocol", IETF RFC 4960.
- Stewart R., (2007), "RFC 4960, Stream Control Transmission Protocol".
- Stewart. R, Ramalho. M, Xie. Q, Tuexen. M, Rytina. I, Belinchon & M,Conrad, (2006), "P Stream Control Transmission Protocol, Dynamic Address Reconfiguration, proposed extension".
- Stewart R., et al., (2007), "Stream Control Transmission Protocol (SCTP) Dynamic Address Reconfiguration", IETF RFC 5061.
- Koh S.,et al., (2004), "mSCTP for Soft Handover in Transport Layer," IEEE Communications Letters, PP:189-191, vol. 8, No. 3.
- Kim K.Y., Ham K.G., Cho K.S. & Choi S., (2011), "Seamless Handover Scheme based on SIP in Wireless LAN", IEEE conference ICACT, PP:847-851.
- Nakajima N., Dutta A. & DAS S., (2003), "Handoff delay analysis and measurement for SIP based mobility in IPV6", ICC'03 IEEE International conference on, DOI: 10.1109/ICC.2003.1204526, PP: 1085-1089, vol 2.
- Camarillo G., Johnston A., Peterson J., Sparks R., Handley M. & Schooler E., (2002), "RFC 3261 SIP: Session Initiation Protocol".
- Rehan M. M., (2009), "Investigation of IEEE 802.21 Media Independent Handover", PhD thesis, Mohammad Ali Jinnah University,
- Kim B., Jung Y. & Kim Y., (2003), "Enhanced FMIPv4 Horizontal Handover with Minimized Channel Scanning Time based on Media Independent Handover (MIH)", Network Operations and Management Symposium Workshops, 2008. NOMS Workshops, doi: 10.1109/NOMSW.2007.11, PP: 52-55.
- Wei G., (2007), "optimisation du handover dans le protocole ipv6 mobile avec la methode e-hcf", Université Paris 12, Val De Marne,
- Zhao Y. & Nie G.; (2009), "A Scheme for Reducing Handover and Packet Loss in Heterogeneous Mobile IPv6 Networks" IEEE 4th International Conference on Computer Science & Education, ICCSE '09. 4th International Conference on, doi: 10.1109/ICCSE.2009.5228431, PP: 339 - 342.
- Khan M.Q. & Andresen S.H., (2011), "Implications of Zero Scanning Time on MIPv6 Handover Delays by Using Media Independent Information Server (MIIS)", Communications (APCC), 17th Asia-Pacific IEEE Conference on, doi: 10.1109/APCC.2011.6152827, PP: 324-329.
- Hong Y., Pawlikowski K. & Sirisena H., (2011), "DAD-Less MIPv6 for Reduced Handover Latency", Innovative Mobile and Internet Services in Ubiquitous Computing (IMIS), Fifth International IEEE Conference on, doi: 10.1109/IMIS.2011.121, PP: 353 – 360,.
- Zhengzhou P.R., (2010), "A Method for Making FMIPv6 Security and Fast Handover Based on Context Transfer Protocol", Wireless Communications Networking and Mobile Computing (WiCOM), 6th International IEEE Conference on, doi: 10.1109/WICOM.2010.5601258, PP:1-4.
- Robert Hsieh', Aruna Seneviratne', Hesham Soliman', Karim El-Malki' (2002), "Performance analysis on hierarchical Mobile IPv6 with fast-handoff over end-to-end TCP", IEEE Global Telecommunications Conference vol.3, Nov. PP: 2488-2492,
- Mussabbir Q., Yao W., Niu Z., & Fu X., (2007), "Optimized FMIPv6 Using IEEE 802.21 MIH Services in Vehicular Networks," IEEE Transactions on Vehicular Technology,PP: 3397–3407.
- Yoo S., Cypher D., & Golmie N., (2008), "Timely Effective Handover Mechanism in Heterogeneous Wireless Networks,"Military Communications Conference, doi: 10.1109/MILCOM.2007.4455128, PP:1-7.
- Jeong J., Shin D.R. & Choo H., (2011), "Performance Analysis of Virtual Layer Handoff Scheme Based on



MAP Changing in HMIPv6 Networks”, High Performance Computing and Simulation (HPCS), International Conference on, doi:10.1109/HPCSim.2011.5999821, PP: 169 – 175.

Liu S., Cai Z. & Gan Y., (2011), “Simulation and analysis of a new MAP selection scheme in F-HMIPv6 network”, Communication Software and Networks (ICCSN), IEEE 3rd International Conference on, doi:10.1109/ICCSN.2011.6014723, pp: 285 – 287.

Chen Y., Wu T. & Lee W., (2011), “A Novel Mechanism to Improve Handover Efficiency considering the Duplicate Address Occurs in HMIPv6”, Advanced Information Networking and Applications (WAINA), 2011 IEEE Workshops of International Conference on, doi:10.1109/WAINA.2011.65, PP:658 – 663,

Zubairi M., Mahfoor S., Khan A. & Rehman W., (2011), “Providing End-to-End QoS in Next Generation Networks (NGNs) using Combined SIP HMIPv6 (CSH)”, Computer Networks and Information Technology (ICCNIT), 2011 International Conference on, doi:10.1109/ICCNIT.2011.6020916, PP: 113 – 118.